

PROCESS DETAILS

Process	EPITAXIAL PLANAR
Die Size	20 x 20 MILS
Die Thickness	7.1 MILS
Base Bonding Pad Area	4.0 x 4.0 MILS
Emitter Bonding Pad Area	4.7 x 4.7 MILS
Top Side Metalization	Al - 30,000Å
Back Side Metalization	Au - 18,000Å

GEOMETRY

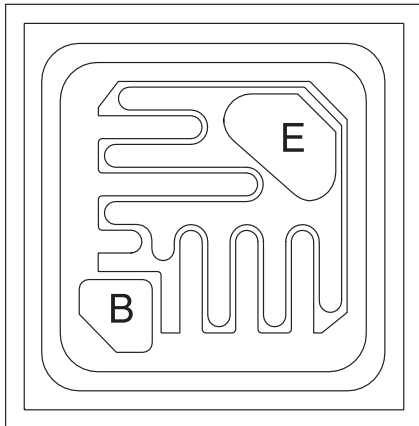

BACKSIDE COLLECTOR R0

GROSS DIE PER 4 INCH WAFER

29,659

PRINCIPAL DEVICE TYPES

CMUT5401

CMPT5401

CXT5401

145 Adams Avenue
Hauppauge, NY 11788 USA
Tel: (631) 435-1110
Fax: (631) 435-1824
www.centalsemi.com

R1 (23- August 2006)

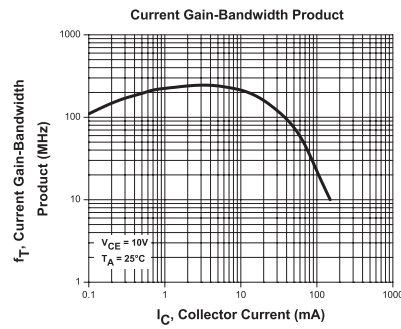
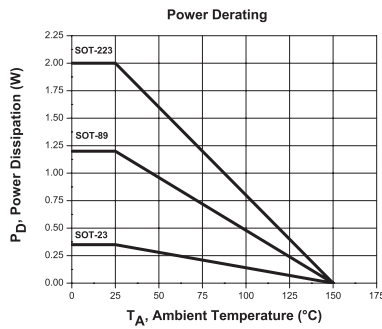
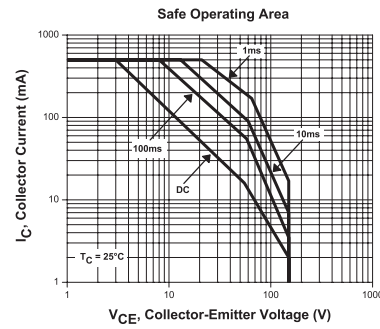
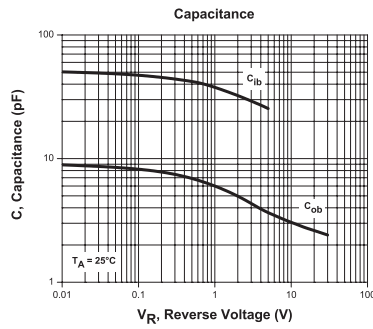
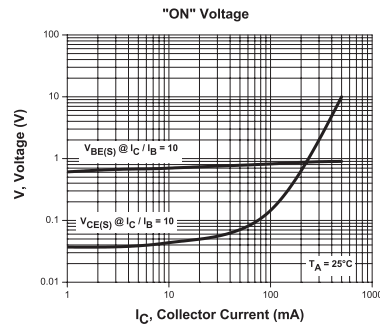
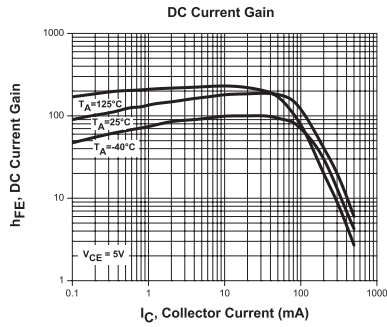

145 Adams Avenue
Hauppauge, NY 11788 USA
Tel: (631) 435-1110
Fax: (631) 435-1824
www.centrasemi.com

R1 (23- August 2006)